

AR LINE



cmatic[®]
P N E U M A T I C F I T T I N G S

Raccordi Automatici Rotanti
Rotary Push-in Fittings
Raccords Instantanés Rotatif
Drehverschraubungen



Raccordi Automatici Rotanti ideali per applicazioni con movimenti rotanti ed oscillanti.



Rotary push-in fittings suitable for applications with rotating and swinging movements.



Raccords rotatives idéales pour des applications avec mouvements de rotation et oscillation.



Drehverschraubungen tauglich bei Anwendungen mit Dreh und Schwenkbewegungen.

AR

1 - 2	3	4	5	6	7	8
Corpo ed Anello Estrattore Body and Release Ring Corps et poussoir Körper und Lösering	Anello di Ritegno Holding Ring Bague de retenue Haltering	Pinza aggraffaggio Gripping ring Pince Spannzange	Anello portapinza Protection Ring Bague protection Schutzring	Guarnizioni Seals Joint d'étanchéité Dichtung	Cuscinetto a sfere Ball bearing Roulement à billes Kugellager	Seeger Seeger Seeger Seeger
Ottone UNI EN 12164 CW614N - UNI EN 12165 CW617N Nichelato Brass UNI EN 12164 CW614N - UNI EN 12165 CW617N Nickel Plated Laiton UNI EN 12164 CW614N - UNI EN 12165 CW617N Nickelé Messing UNI EN 12164 CW614N - UNI EN 12165 CW617N vernickelt	Resina Acetalica (POM) Acetal Resin (POM) Résine acétal (POM) Azetalharz (POM)	Acciaio INOX AISI 301 Stainless steel AISI 301 Acier Inox AISI 301 Edelstahl AISI 301	Resina Acetalica (POM) Acetal Resin (POM) Résine acétal (POM) Azetalharz (POM)	NBR NBR NBR NBR	Acciaio 100Cr6 Steel 100Cr6 Acier 100Cr6 Stahl 100Cr6	Acciaio INOX AISI 302 Stainless steel AISI 302 Acier Inox AISI 302 Edelstahl AISI 302



-20°C ÷ 80°C



Max 20 bar

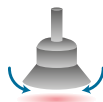

-99 KPa



Ø Tube	Ø4	Ø6	Ø8	Ø10	Ø12
Numero di giri Number of turns Numero de tours Drehzahl	500 rpm	500 rpm	400 rpm	300 rpm	250 rpm

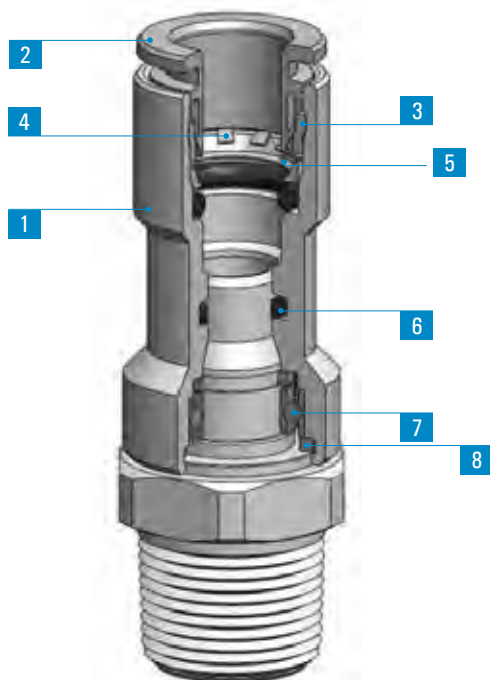

	R1/8	R1/4	R3/8	R1/2
4	•			
6	•	•		
8	•	•	•	
10		•	•	•
12			•	•

SPECIFICHE TECNICHE

Tubi di collegamento consigliati:
Tubo in Poliuretano (PU); si sconsiglia l'uso di tubi rigidi.

Campi di applicazione:
Impianti pneumatici.



Evitare carichi laterali sul tubo che possono generare carichi eccessivi sul cuscinetto compromettendone rotazione e durata.

DATA SHEET

Recommended tubings:
Polyurethane (PU); rigid tubings are not recommended.

Application fields:
Pneumatic circuits.



Avoid side loadings on the tube to prevent overloads on the bearings. This could affect rotation as well as the product lifetime.

REINSEIGNEMENTS TECHNIQUES

Tubes conseillés:
Polyuréthane (PU); les tubes rigides ne sont pas conseillés.

Domaines d'application:
Circuits pneumatiques.



Eviter les charges latérales sur les tuyaux qui peuvent engendrer des charges excessives sur les roulements et compromettre la rotation et la durée du raccord.

TECHNISCHE AUSKÜNFTE

Empfohlene Schläuche:
Polyurethan (PU); starre Schläuche sind nicht empfohlen.

Anwendungsbereiche:
Pneumatik



Seitenlast am Schlauch vermeiden, die zur übermäßigen Belastung auf die Kugellager führen könnte und dadurch die Rotationen und Lebensdauer der Verschraubung beeinträchtigen.

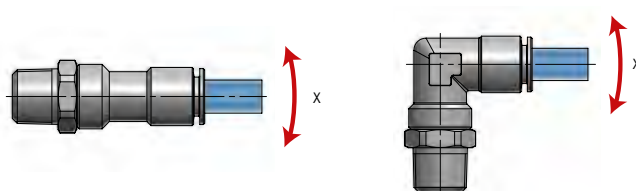

Profondità di inserimento del tubo

Tubing insertion depth

Profondeur d'insertion du tube

Schlaucheinstecktiefe

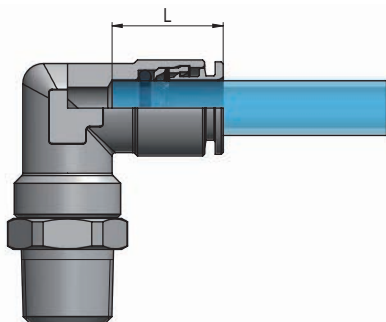

Ø _e Tube	L
4	13,2
6	16,1
8	16,2
10	18,3
12	19,5

ISTRUZIONI DI MONTAGGIO

ASSEMBLY INSTRUCTIONS

INSTRUCTIONS DE MONTAGE

MONTAGEANWEISUNGEN

1. Tagliare il tubo a 90° (servendosi della pinza tagliatubo TCUT) verificando l'assenza di bave interne ed esterne e facendo attenzione che il tubo non si presenti ovalizzato dopo il taglio.
2. Inserire il tubo nel raccordo spingendolo fino in battuta.

1. Cut the tube square (by means of a hose cutter i.e. our TCUT) making sure that no burrs are left and that the tube is not oval.
2. Insert the tube into the fitting until it bottoms.

1. Sectionner le tube à 90° par notre coupe tube TCUT en prenant soin de ne pas créer des bavures et de ne pas ovaliser le tube.
2. Pousser le tube jusqu'au fond du raccord.

1. Schlauch mittels unserer Schlauchscher (TCUT) 90° abschneiden und entgraten.
2. Darauf achten, daß der Schlauch danach nicht oval gequetscht ist und dann ihn bis zum Verschraubungsanschlag einstecken.

Estrazione del tubo

Esercitare una leggera pressione sull'anello estrattore, estraendo contemporaneamente il tubo dal corpo del raccordo.

Tube release

While pressing on the release ring, pull out the tube from the fitting.

Débranchement du tube

Appuyer sur le poussoir en métal et tirer simultanément sur le tube.

Schlauchlösen

Auf den Druckring drücken und gleichzeitig den Schlauch rausziehen.

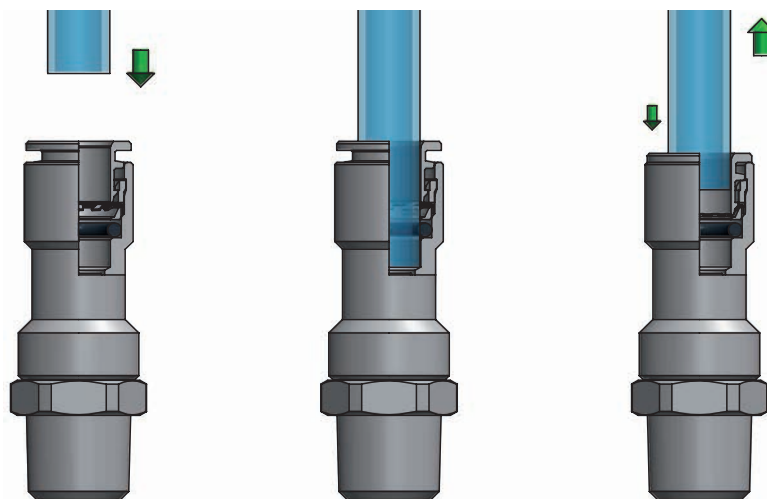

Effettuato il collegamento, assicurarsi che il tubo inserito nel raccordo non sia sottoposto ad alcuna forza di trazione; è necessario inoltre rispettare durante il collegamento del tubo il raggio minimo di curvatura consigliato così come riportato nella sezione tubi di questo catalogo tecnico (vedi pag. 363). Al fine di evitare lo sgancio involontario del tubo nessun oggetto deve venire a contatto con l'anello estrattore del raccordo evitando così l'esercizio di qualsiasi forza indesiderata, anche solo laterale, che potrebbe causare la pressione dell'anello estrattore e conseguente rilascio del tubo. Per il serraggio delle parti filettate del raccordo si raccomanda di attenersi alle coppie consigliate riportate a pag.6.



Once the tubing is connected to the fitting, make sure that the tubing is not subject to any tensile strength and that the min. recommended bending radius stated in the tubing section of this catalogue is complied with (see page 363). To prevent any accidental tube release, no components have to come in touch with the release ring and exercise any unwanted pressure on the same. Indeed however lateral, any load on the release ring may cause the tube disconnection. To tighten threads, please check out our tightening torque chart illustrated at page 6.



Une fois effectué le branchement, s'assurer que le tube inséré dans le raccord n'est soumis à aucune force de traction. Egalement, il est nécessaire de respecter, lors du branchement du tube, le rayon minimum de courbure conseillé dans la section tubes de ce catalogue technique (voir la page 363). Afin d'éviter le décrochage involontaire du tube, aucun objet ne doit entrer en contact avec la bague d'extraction du raccord, empêchant ainsi l'exercice de toute force indésirable, ne serait-ce que latérale, qui pourrait provoquer la pression de la bague d'extraction et donc le relâchement du tube. Pour le serrage des parties filettées du raccordo, il est recommandé de s'en tenir aux couples de serrage conseillés et reportés à la page 6.



Nach der Schlauchverbindung, sicherstellen, dass der in die Verschraubung eingeführte Schlauch keinen Zugbelastungen ausgesetzt ist; beim Anschluss des Schlauchs muss der empfohlene Mindestbiegeradius eingehalten werden, gemäß den in diesem technischen Katalog im Schlauchabschnitt, angegebenen Hinweisen (siehe Seite 363). Um das versehentliche Lösen des Schlauchs zu verhindern, darf kein Gegenstand den Lösering der Verschraubung berühren. Keine unerwünschte Kraft darf auch nicht seitlich einwirken und kein Druck soll auf den Lösering ausgeübt werden, denn dies das Schlauchlösen verursachen könnte. Zum Festziehen der Gewinde sich an den, auf Seite 6, empfohlenen Drehmomente einhalten.

AR 11

Diritto maschio Conico rotante

Straight male fitting, rotating

Raccord droit mâle, rotatif

Einschraubverschraubung,
rotatorisch

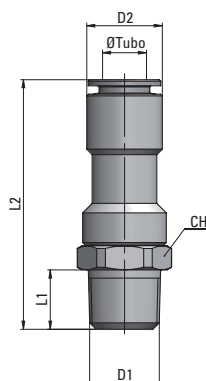

Type	Ø Tubo	D1	D2	L1	L2	CH	g Δ
11 04 18	4	R1/8	9	7,5	37,7	13	18,6
11 06 18	6	R1/8	12	7,5	40,1	13	22,5
11 06 14	6	R1/4	12	11	44,1	14	25,8
11 08 18	8	R1/8	14	7,5	42,6	16	31,3
11 08 14	8	R1/4	14	11	46,1	16	33,5
11 08 38	8	R3/8	14	11,5	47,1	18	38,5
11 10 14	10	R1/4	16	11	52,6	22	58,7
11 10 38	10	R3/8	16	11,5	53,1	22	-
11 10 12	10	R1/2	16	14	55,6	22	-
11 12 38	12	R3/8	19	11,5	54,6	22	73,6
11 12 12	12	R1/2	19	14	57,1	22	80,1

AR 15

Gomito maschio conico rotante

Elbow male fitting, rotating

Raccord à coude, rotatif

L- Einschraubverschraubung,
rotatorisch

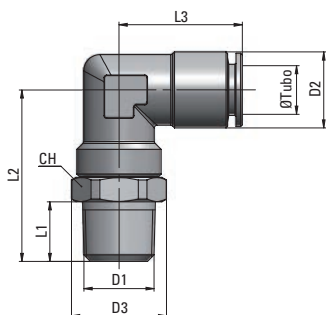

Type	Ø Tubo	D1	D2	D3	L1	L2	L3	CH	g Δ
15 04 18	4	R1/8	9	14,5	7,5	25,3	19,5	13	21,6
15 06 18	6	R1/8	12	14,5	7,5	25,3	22	13	24,5
15 06 14	6	R1/4	12	15,5	11	29,3	22	14	27,9
15 08 18	8	R1/8	14	17,5	7,5	28,1	22,5	16	40,1
15 08 14	8	R1/4	14	17,5	11	31,6	22,5	16	41,8
15 08 38	8	R3/8	14	20	11,5	32,6	22,5	18	47,5
15 10 14	10	R1/4	17	24	11	37,1	26,5	22	85,5
15 10 38	10	R3/8	17	24	11,5	37,6	26,5	22	89
15 10 12	10	R1/2	17	24,5	14	40,1	26,5	22	94,1
15 12 38	12	R3/8	19	24	11,5	38,6	28,5	22	90,3
15 12 12	12	R1/2	19	24,5	14	41,1	28,5	22	96,1